

INSTALLATION MANUAL

LABORATORY CASEWORK & FUME HOODS

INTRODUCTION

At Scientifix we are constantly striving to provide our customers with the finest laboratory furniture, using the best quality materials and workmanship available. Even the finest laboratory furniture is satisfactory and functional only when properly installed. Scientifix can supply our customers with trained and experienced supervisors or we can provide a complete installation at your request.

If you choose to attempt an installation on your own, we will supply the necessary information to assist you in doing so. This manual represents part of that service. Since no manual could possibly cover all of the situations that might be encountered during the course of construction, your Scientifix sales representative and project manager are always ready to offer their services to ensure that the installation is completed to your satisfaction.

Each jobsite is a little different. Whether it is a renovation or a new building, uneven floors, crooked walls, no loading dock, and limited access corridors are just some of the normal conditions that must be overcome. The following are typical operations that would be performed by installation technicians to suit varying jobsite conditions.

- Receiving, unloading and unpacking all items.
- Checking material for damage and reporting any missing items.
- Dismantling fume hoods or equipment to fit through door openings.
- Reading shop drawings and setting all furniture in place.
- Scribing, shimming, and leveling.
- Cutting and trimming various counter top materials.
- Cutting sink opening in plastic laminate counter tops.
- Notching and fitting tops and curbs to accommodate pipes, electrical conduit, ductwork, and columns.
- Drilling holes in counter tops and furniture.
- Notching cabinet rails.
- Cutting aprons and knee space panels to suit available openings.
- Adjusting and or setting locks.
- Cutting, notching, and scribing all filler panels.
- Resetting hinges and catches when adjusting the fit of doors and drawers.
- Retouching units and tops that have minor scratches.

Note – always double check you shop drawings and verify all dimensions before altering any items. An improperly cut top or panel may take several weeks to replace. Scientifix will gladly provide an installation quote, upon request.

PREPARATION CHECK LIST

In order that the installation proceeds smoothly and efficiently, and to avoid damage to you new furniture and worktops, the following items must be completed **before** installation can begin:

- All windows and doors are in place.
- All necessary services are roughed-in.
- Floor tile or other finished flooring is complete.
- Overhead ceiling work is complete.
- Walls are in their proper finished state, i.e. Painted or other finish.

BASIC INSTALLATION STEPS

Not all of the following steps may apply to your particular laboratory installation. Details for each step, as it applies to your lab, are enclosed in this manual.

- Hanging wall cabinets.
- Install Unistrut assemblies, where called for.
- Set in place, level, and fasten base cabinets together.
- Dry fit all worktops.
- Glue down worktops and finish the seams.
- Install fume hoods.
- Mount fume hood exhaust blower units.
- Set sinks and service fittings into worktops.
- Make final plumbing, electrical and ductwork connections.
- Install end closures, service panels, and filler panels.
- Cement cove base molding in place.
- Caulk all furniture that attaches to walls.
- Clean and touch-up cabinets and worktops where required.

Please note that Scientifix does not supply tools, screws, glue, caulk, or other fastening devices of any kind. We will only supply items if they are specifically required and are clearly listed on our quotation as being part of the furniture contract.

REQUIRED TOOLS

- Claw Hammer
- Rubber Mallet
- Two Foot & Four foot Levels
- Right-Angle square
- 30 foot Steel Tape Measurer
- Assorted screw drivers
- Adjustable Wrench
- Center Punch
- Hack Saw
- Putty Knives
- Pipe Clamps
- Carpenters Clamps
- Extension Cords
- ½" Electric Drill
- ½" Hammer Drill
- Carbon steel drill bits (assorted sizes, masonry included)
- Diamond grit drill bits (assorted sizes)
- Countersink bits
- Hole Saws (various sizes)
- Skill Saw (diamond and carbide blades)
- Electric Screw Gun
- Jig Saw
- Electric Tin Snips
- Right and Left Hand Tin Snips
- Saws All (reciprocating saw)
- Rivet Gun
- Caulk Gun

FASTENING DEVICES

- Flat Head & Counter sink Head screws: (2 ½") (1 ½") & (¾") #10 Cadmium plated
- Self drilling/Self tapping screws (Zap screws)
- Nylon screw anchors, Toggle bolts, Tap Cons, Rawl plugs.
- #10 Finishing washers
- 1/8" x 1/8" Steel rivets
- Epoxy resin (2) part glue

INSTALLATION OF WALL CABINETS

Extra care should be taken in selection of fasteners when installing wall cabinets, due to the weight factor and existing wall construction.

Wall cabinets are usually installed before the base units to avoid climbing over benches or on cabinets with sliding doors. It is recommended that the doors and shelves be removed before installing.

Determine the correct height for the unit to be hung. Always start your measurement from the highest point of the floor. Take care not to conflict with any service fittings to be installed below. Mount strapping in an appropriate location on the wall – see illustration (Fig. 1). When strapping is safely secured to the wall. Lift the cabinet into position, level and secure to the strapping with a minimum of two fasteners per strap.

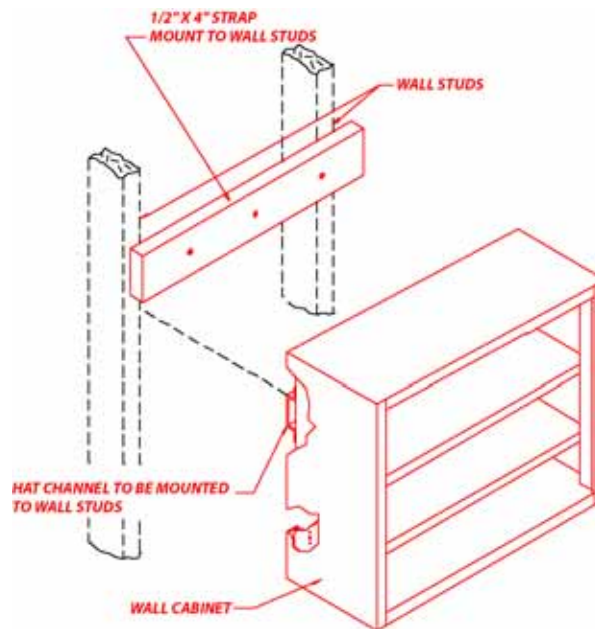

WALL CABINET INSTALLATION (Fig. #1)

INSTALLATION OF UNISTRUT

Before Unistrut can be installed it is important to determine the high point of the floor in order to avoid the risk of having worktops that are not level.

With a 48" level and straight edge (the longer-the better), determine the highest point. When this is complete, proceed with the installation of the Unistrut commencing at the high point.

Standard Unistrut box assemblies consist of two lengths of "U" channel and two mild steel "U" brackets bolted to the main channel members. Spring nuts, (which slip inside the channel), and 3/8" hex head bolts. Assemble Unistrut as shown in the illustration below.

Adjust the height to suit your base cabinets- 34 3/4" for standing units and 28 3/4" for sitting height units. Space the Unistrut evenly along the elevation where they are required. Check your shop drawings for the location of service fittings and sinks and ensure that the Unistrut is positioned so as not to interfere with them. Fasten the "U" channel to the wall. Secure the bottom "U" bracket to the floor.

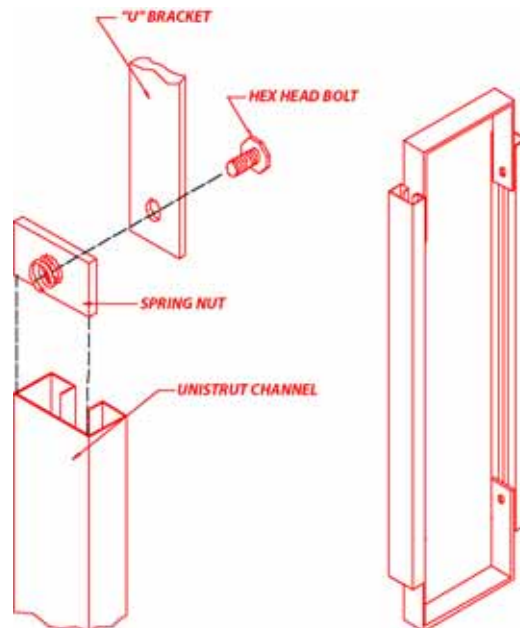

UNISTRUT BOX ASSEMBLY INSTALLATION

INSTALLATION OF BASE CABINETS

See illustration below for typical base cabinet details.

To avoid having worktops that are not level, base cabinets must be installed commencing at the highest point in the floor. Use a 48" level and a straight edge to determine which end of the floor is high. Starting at the higher end, set cabinets in place according to the shop drawings. Where service lines are to be run behind the base cabinets, make sure that the proper clearance is maintained between the unit and the wall. Note that back panels are supplied on cupboard units only. All drawer units are open for easy access to service lines.

Remove shelves and/or drawers, noting their location for re-installation. Next, level the cabinets. Leveling bolts are provided beneath the press plugs located in the four corners of the cabinet floor. Using a hex head Nut-driver, adjust the leveling bolts as needed while using the level. Repeat this process for each cabinet. When all units have been positioned and leveled, fasten them together using self-drilling/self-tapping #8 screws. Locate the screws at the top, bottom and rear of cabinets. Replace shelves and drawers.

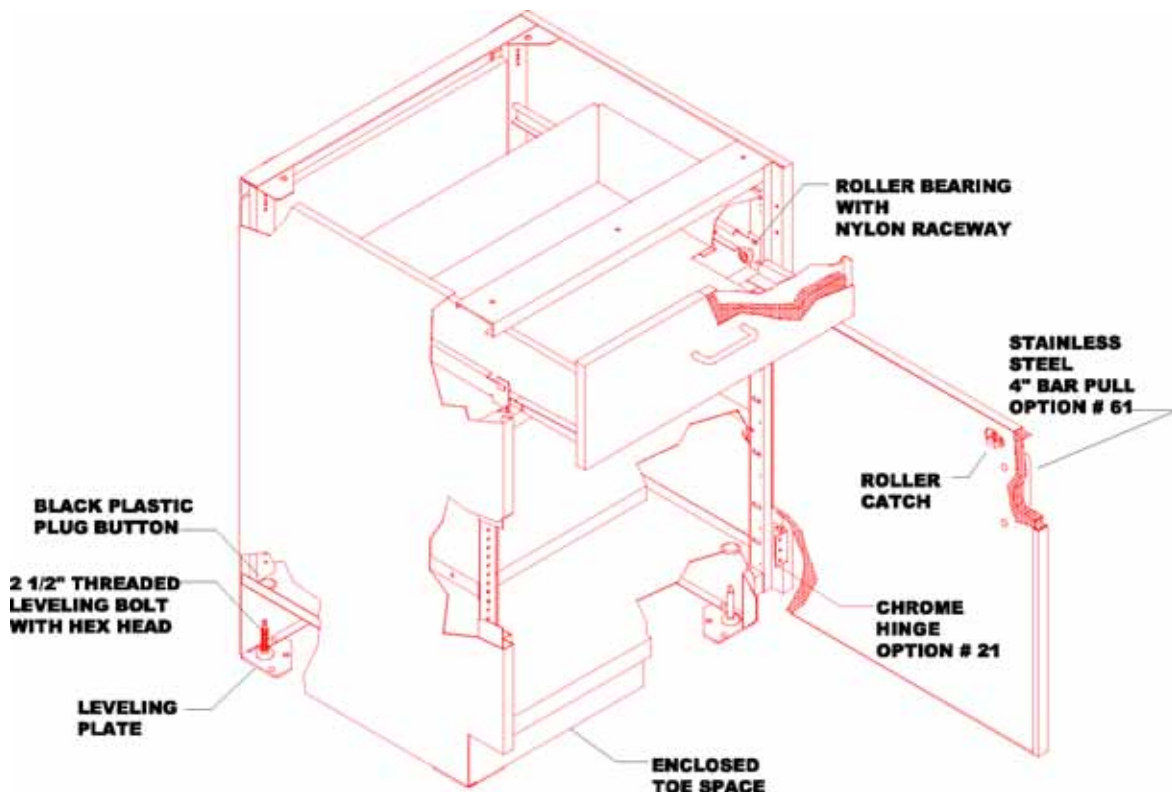

INSTALLATION OF END COVER SCRIBE PANELS

Wall end cover panels consist of two parts – a flat mild steel panel with a formed brake on one long edge and a double mounting angle. Island end cover scribes are formed in a single channel. End cover scribe panels are used to close off the rear pipe chase at the end of a wall or island bench.

On island benches, secure the brakes of the channeled end closure panel using three ½" #8 self-drilling self-tapping screws (each brake).

See illustrations below for details.

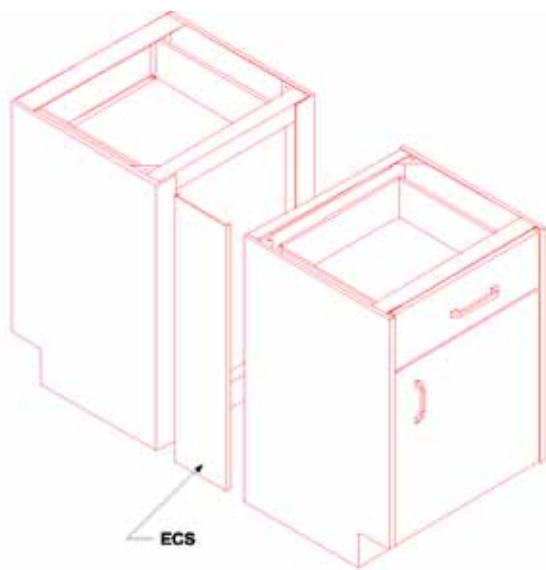

ECS INSTALLATION FOR ISLAND BENCH

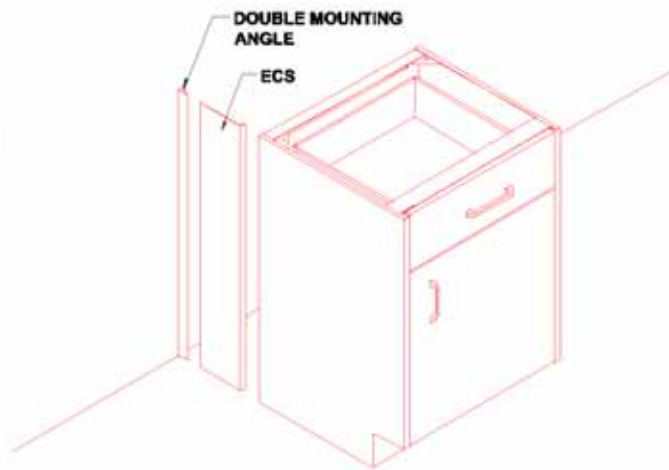

ECS INSTALLATION FOR WALL BENCH

INSTALLATION OF FRONT FILLER SCRIBE PANELS

Front filler scribe panels are supplied to fill in a gap between base units and walls. Each panel has a finished face to match the base cabinets and a solid flange on each side.

Scientifix will supply an over sized filler which must be cut to suit on site. Scribe the filler using metal shears. Fasten the flanged side to one cabinet. Screw a double angle to the other cabinet or wall and slip the cut edge of the filler into the slot in the angle.

See illustration below for details.

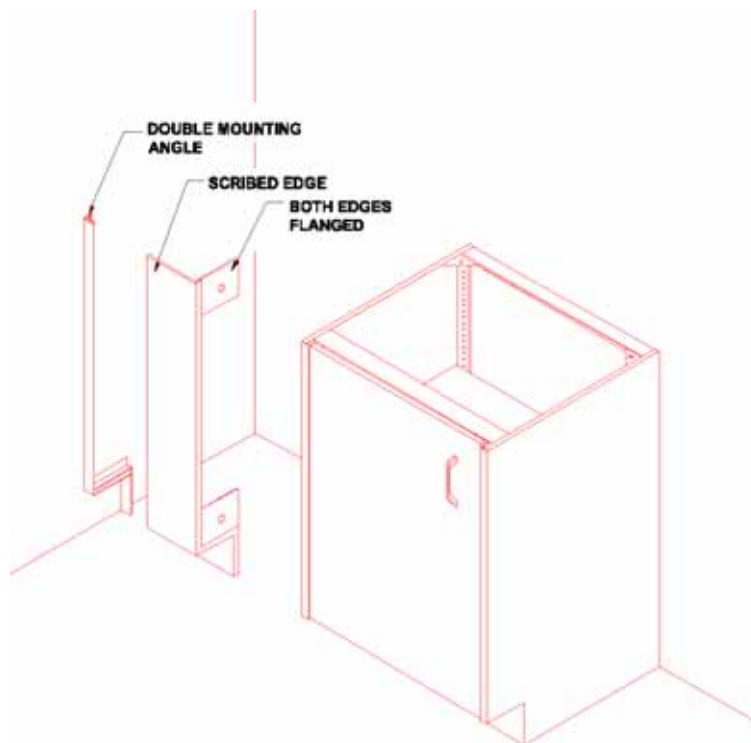

FRONT FILLER PANEL INSTALLATION

INSTALLATION OF APRON UNITS & FRONT RAILS

Since apron units and front rails can readily be cut to suit available openings, they can be installed after all the other cabinets are in place.

To install an apron unit, remove the drawer, slip the end caps over the front and back rails and temporarily clamp the unit in place. Drill a 1/8" hole through the top flange of the cap and rail in both the front and back, and secure the rails to the caps with four 1/8"x1/8" steel rivets. Then, fasten the apron unit to the adjacent cabinet and or pedestal leg using 1/2" #8 self-drilling self-tapping screw. Front (plain) rails are installed in the same manner.

If it is necessary to reduce the overall length of your bench, apron units or front rails may be cut down to suit the required opening.

Where apron units or rails are supplied at the end of a bench, a pedestal leg or "H" leg assembly will be provided. When legs are specified, the apron frame will be notched to accept the leg(s). Pass the threaded bolts of the legs through the holes in the frame corners and secure with the washer and nut supplied. Do not over tighten.

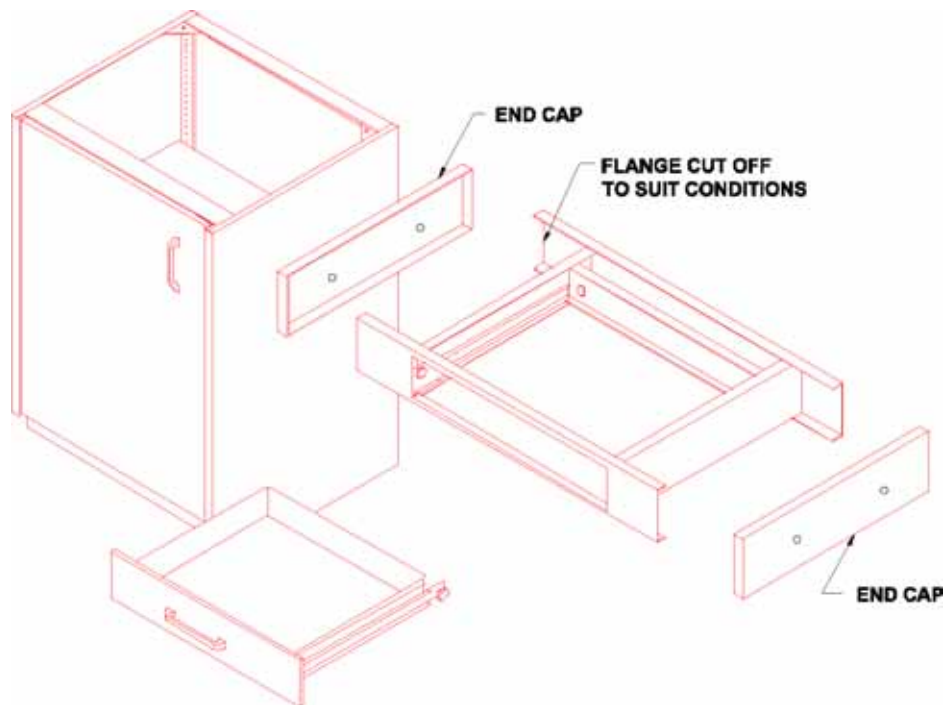

FRONT RAIL & APRON INSTALLATION

INSTALLATION OF SERVICE COVER PANELS (KSP)

Service cover panels (KSP) are used to close off the pipe chase at the rear of a knee space assembly or service strip. Each service cover panel consists of four parts. (2) Angles, (1) large upper panel and (1) smaller lower panel with a formed edge (base plate). Since these items can be cut to suit the available space, as well as left open for easy access to the plumbing lines, they are usually among the last items to be installed.

First, secure the angles to the adjacent base cabinets and or wall. These angles are fastened to the sides of the opening and project out of the cabinet or wall about 2". Locate the angles below the bottom of the apron or rail (if used) and fasten with (3) ½" #8 self-drilling self-tapping screws. Secure each of the cover panels (Lower then Upper).

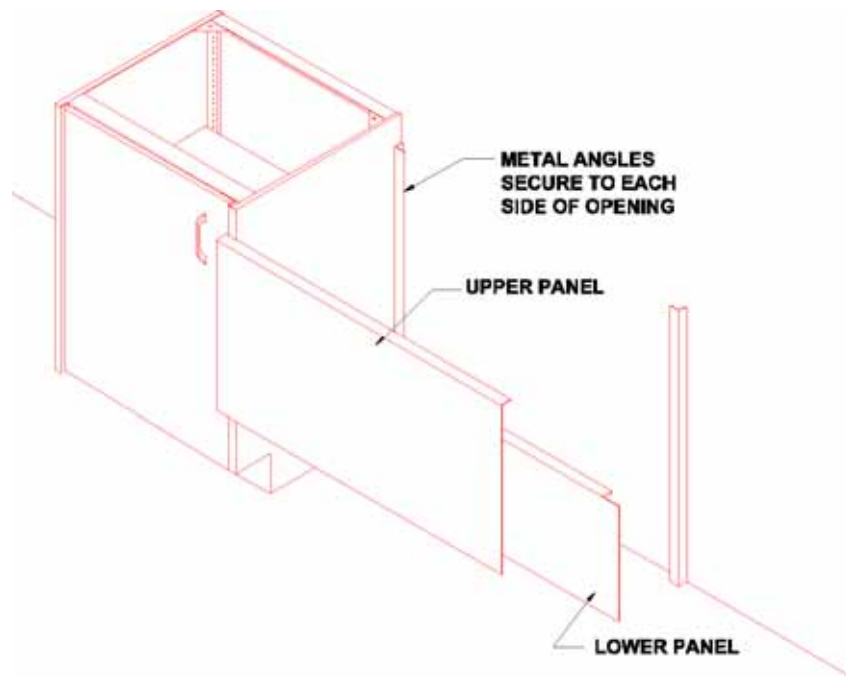

SERVICE COVER PANEL (KSP) INSTALLATION

INSTALLATION OF ADJUSTABLE CORNER FILLER PANELS

Where two elevations of base cabinets meet at an inside corner, a provision must be made for at least 1" clearance each way to permit drawers to operate freely. An inside corner is also a good spot to take up any slack in a wall-to-wall assembly. Corner filler panels fulfill both purposes.

One corner filler panel unit consists of one 1" wide filler, one 18" wide filler, and one angle 6" x 6". Using ½" #8 zap screws, secure the 1" filler to the side of one base cabinet. The longer filler is secured to its adjacent cabinet. At this point, make sure all cabinets are in their final position- properly leveled and screwed together with no gaps. The longer filler should overlap the shorter filler, leaving at least 1" of each filler piece exposed at the corner. Fasten the fillers together using ½" #8 zap screws. The remaining hole at the floor is then closed off with the 6" x 6" angle (toe kick filler).

Adjustable fillers allow each elevation to be adjusted left/right as needed.

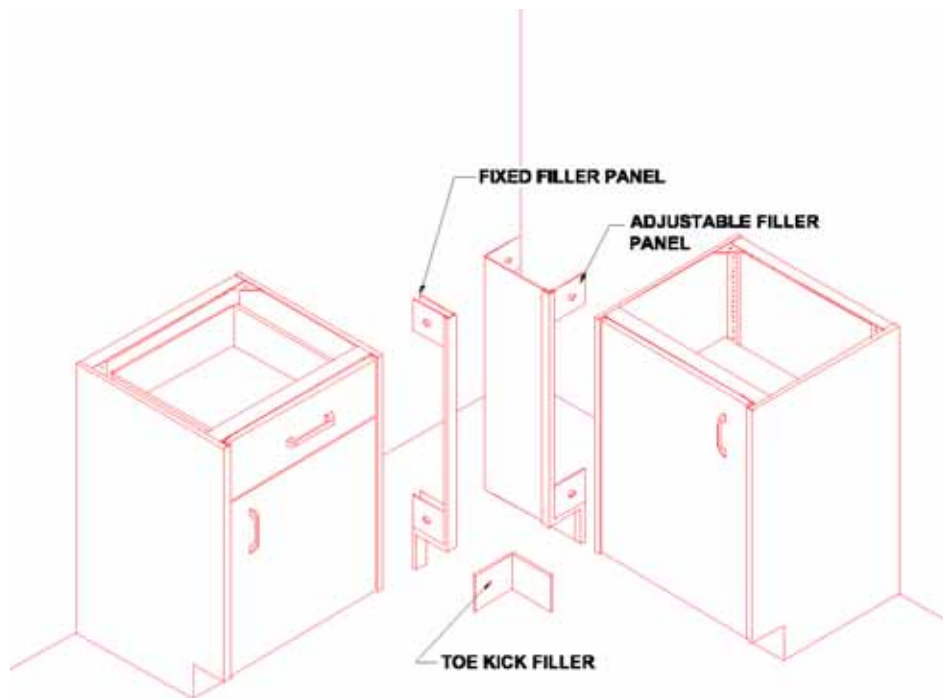

ADJUSTABLE CORNER FILLER INSTALLATION

INSTALLATION OF BENCH MOUNTED FUME HOODS

Remove crating, if present, and examine the hood for concealed damage. If damage is noted, save crate and call Scientifix for further inspection.

On hoods with vertical sliding sashes, the sash counter balance weight must be attached before the hood is removed from the skid. With rollers on weight extending toward the hood, insert the sash cable loop into place between the back of weight and the tab. Bolt in place with bolt head towards the hood wall. Check that the cable is not twisted and is seated properly in all pulleys.

Remove shipping tape on the fume hood exterior. Tape adhesive residue must be cleaned. Remove the side panels by pulling at the top of the panel as close to the front of the hood as possible to disengage from the concealed clips.

Base cabinet(s) should be installed and leveled, and the worktop(s) set into position. (Exceptions – Perchloric acid and Radioisotope hoods have integral work surfaces). A 2" x 2" angle is provided for supporting the fume hood at the wall. Level the angle with the cabinets and secure to the wall using the proper fasteners. Lift the fume hood by the corner posts **only** do **not** lift by the airfoil. Set the hood into position on the worktop. The fume hood front stiles overhang the worktop.

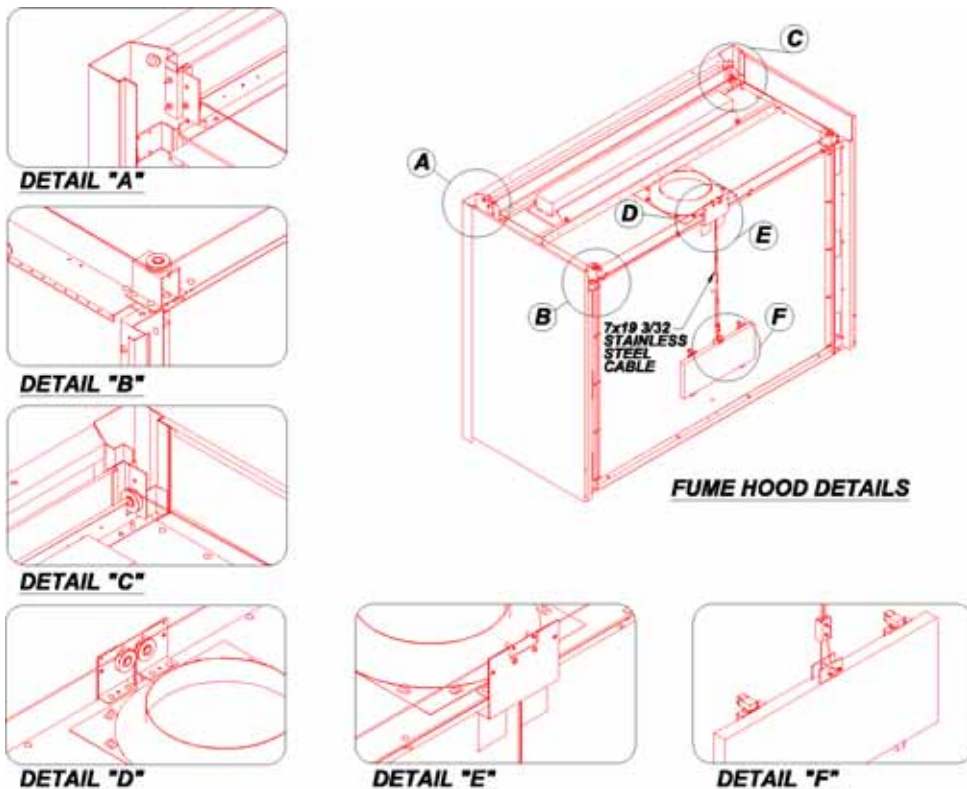

INSTALLATION OF REAGENT TURRETS

Regardless of the counter top material specified, steel reagent turrets are supplied in painted inverted U-shaped tubular supports or box assemblies. The preferred shelving material is Phenolic resin. The turrets must be installed after the worktops are joined and secured to the base cabinets.

Layout on the top, the exact location of the turret supports. These are usually positioned 1" in from the finished ends of the tops. If supplied, refer to the specific set of shop drawings for your project. Mark the position of the U-clips (supplied with turret supports) and pre-drill two holes per clip. Secure clip to the counter top. Repeat the steps above for each turret support. The distance between each support will be clearly shown on your shop drawings. Slip the turrets over the clips and fasten to the clips from the inside of each leg.

Next, set the reagent shelf on the top of the supports. Keep the overhangs on each end of the shelf evenly spaced. Screw the reagent shelf down to the turret supports from the underside of the supports. Two screws per support are required.

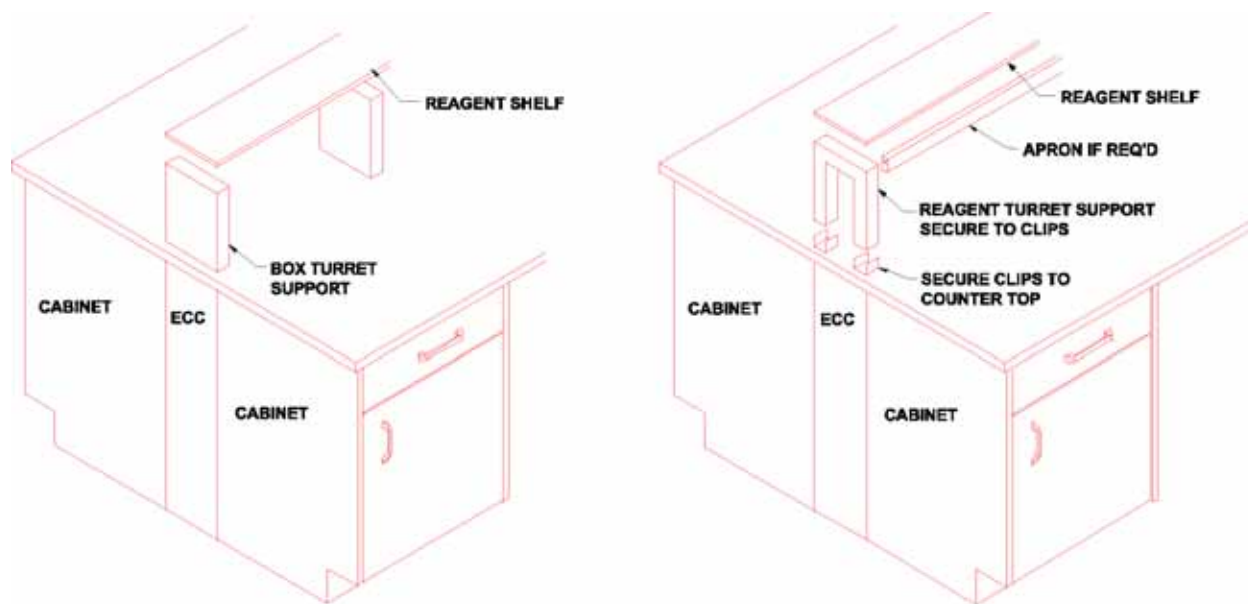

REAGENT TURRET INSTALLATION

INSTALLATION OF EPOXY RESIN WORKTOPS

Use Scientifix shop drawings (if applicable) to allocate each top in its proper location. First, "Dry-Fit" each elevation of counter tops prior to fastening them to the base cabinets. To join tops together, first wipe surfaces to be joined with lacquer thinner. Spread a thin layer of epoxy resin glue along each edge. Pull the tops together and align the seam so that the front and top edges are flush. Remove all excess glue with a putty knife (avoid scratching the tops). Clean up the joints using a soft cloth and warm water. The epoxy resin glue may shrink when hardened. If a final skim coat is required, repeat the process above.

Bench tops may be bonded to cabinets using screws and screw anchors, but adhesive bonding is recommended as the best method. The bonding area on the furniture, as well as the underside of the tops, should be sanded with coarse sandpaper. Remove all sanding dust with lacquer thinner. Apply a bead of sealant to the sanded areas and set the tops in place, allowing a 1" overhang at the front and each end of an assembly. Set all rear and side curbs in the same manner. Fill the seam between the worktop and curb.

INSTRUCTIONS FOR USING EPOXY CEMENT

Epoxy cement may be used for jointing and fastening the tops to the casework. Mixing instructions are printed on the cement container. All parts to be joined together must be clean and free of dirt and grease. A rough surface will form a stronger joint than a smooth surface, so use coarse sandpaper where required. Epoxy cement will harden in about 30 minutes at 73°F. The actual curing time will vary with temperature and humidity. Masking tape may be used to keep the epoxy cement from finished surfaces, but the tape must be removed before the epoxy cement hardens. Before it fully hardens, epoxy cement may be removed with a putty knife and a damp rag.

INSTALLATION OF UNDER COUNTER EPOXY RESIN SINKS

These sinks are designed for under counter mounting in epoxy resin worktops. The cut out in the top should be 1" smaller than the inside dimension of the sink. Run a bead of sealant around the top edge of the sink. Adjust the sink so that it is centered in the cutout. Raise the adjustable support channels until the sink is flush with the underside of the worktop. Install the sink outlet and fill the annular space around the outlet with additional sealant. Do not use epoxy resin cement for the outlet.

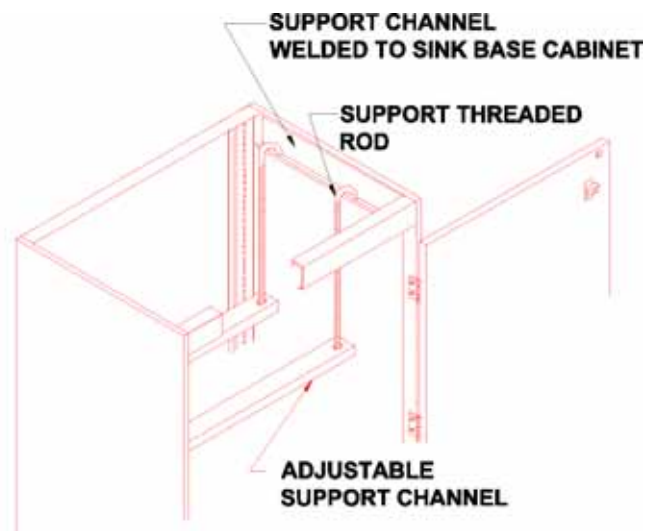

EPOXY RESIN SINK INSTALLATION

FINAL INSPECTION PRE-PUNCH LIST

Check that all pieces of hardware, such as door catches, striker plates and rubber or felt bumpers, are installed and operating properly. Adjust catches, if required.

Remove all clamps from worktops and inspect each seam for imperfections. Correct all seams as needed. Cover/protect all work tops during installation and after final inspection.

If a cabinet has not been leveled properly, it may twist slightly out of square, causing doors and drawers to stick. Using a rubber mallet, give the corner that is binding several sharp blows. This will generally correct the problem. Adjust all doors and drawers so that they have even reveals.

Applying a dab of lubricating grease such as Vaseline, to the roller bearings of the drawer runners will ensure a free quiet operation of the drawers.

Occasionally, a countertop will sit low on cabinets causing drawer or door tops to catch under it when opened. Shim the top with a thin wedge between the cabinet frame and the worktop.

Cabinets that have been slightly scratched or nicked during shipping or installation may easily be touched up. Scientifix supplies small quantities of color-matched paint for this purpose.

If you require additional help please contact your local Scientifix, LLC sales support person.