

## OVERHEAD SERVICE CARRIERS

### Overhead Service Carriers

Overhead Service Carriers can be suspended or flush mounted from the ceiling of the laboratory and are available in continuous linear configurations that run the length of the room, or single units that are located on a grid pattern throughout the lab space. Overhead service carriers are designed to house services such as electrical, data, telephone, and all of the usual plumbing services, thus providing maximum flexibility by eliminating obtrusive services originating from the floor. These service carriers can also support light fixtures and snorkel exhausts. Quick disconnects enable mobile carts and tables to be plugged-in for quick and easy relocation.

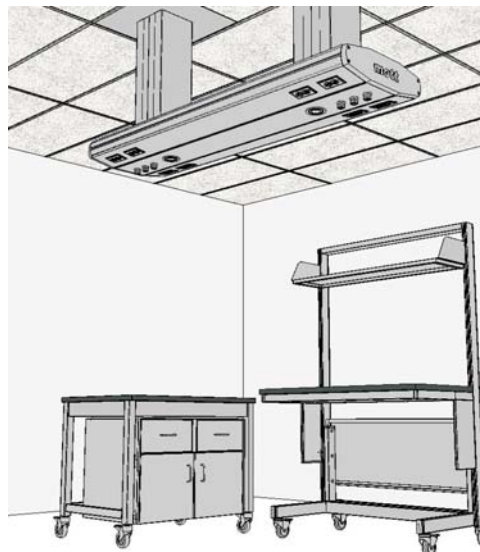
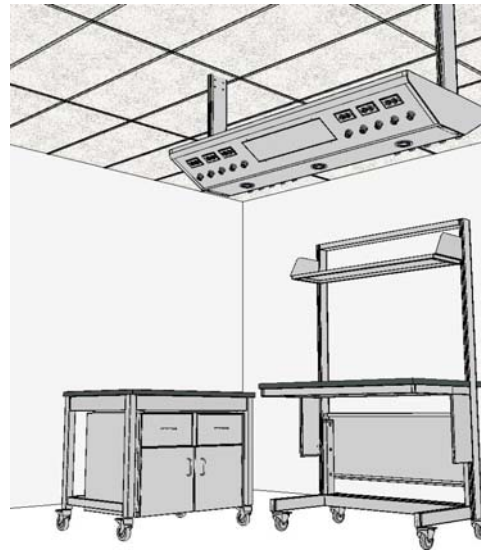
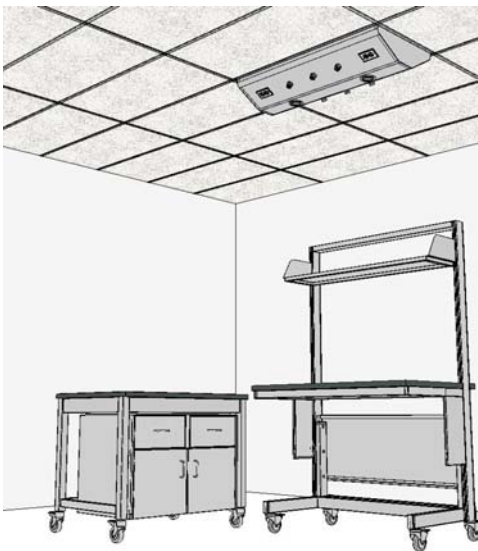

**OVERHEAD SERVICE CARRIERS**

**Suspended Chameleon™**

Suspended Chameleons™ are hung from the ceiling. They can house utilities like piping, electric, data, light fixtures, and snorkel exhausts. They provide maximum flexibility as services are lifted off the floor, allowing free floor space to be configured as needed. They are height adjustable, available in various widths and come with the option of lighting.

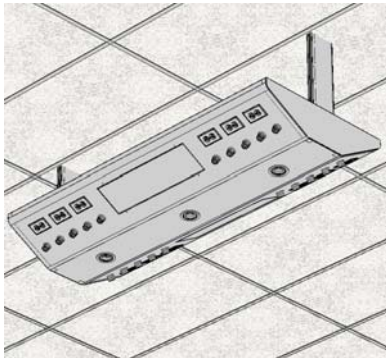

**Suspended Chameleon™ Views**

**Bottom Views**

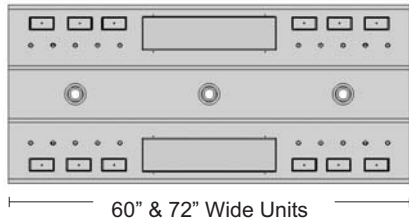

Note: Above units shown with optional lights.

**Side View**

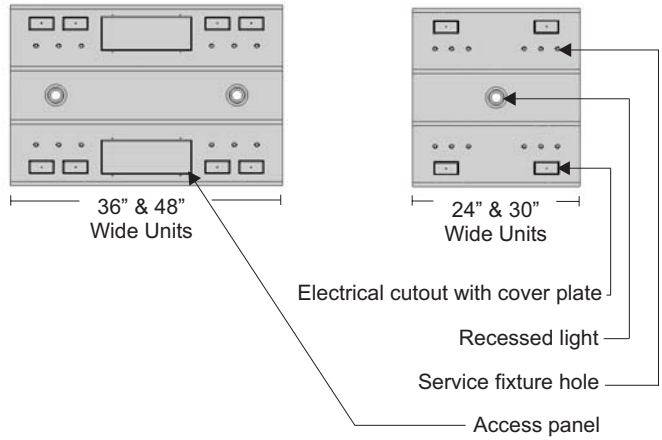
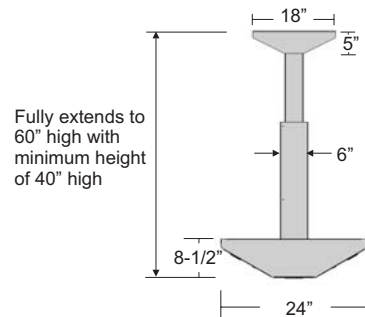

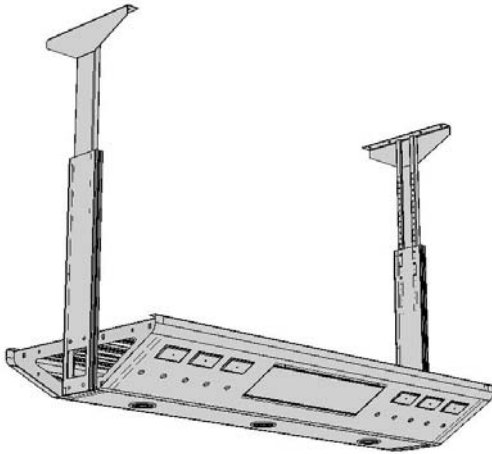
**OVERHEAD SERVICE CARRIER**
**Suspended Chameleon™ With Lights**

Width	Item Number
24"	OHC1024
30"	OHC1030
36"	OHC1036
48"	OHC1048
60"	OHC1060
72"	OHC1072

- Junction boxes are factory installed.
- Fixture holes are plugged with ABS plastic caps.
- Carrier Body is 8-1/2" high x 24" deep.
- Height adjustable in 1" increments.
- End Caps must be ordered separately.
- See page J13 for configurations.

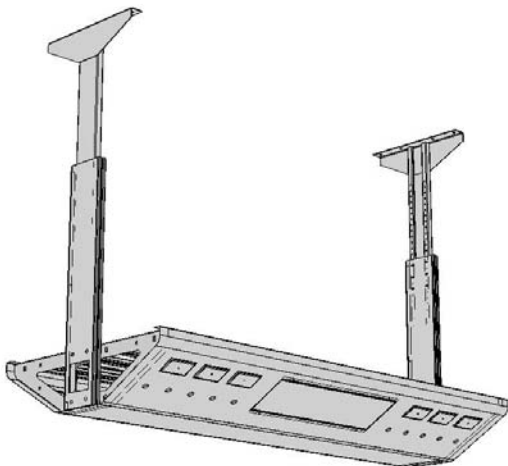
**Suspended Chameleon™ Without Lights**

Width	Item Number
24"	OHC2024
30"	OHC2030
36"	OHC2036
48"	OHC2048
60"	OHC2060
72"	OHC2072

- Junction boxes are factory installed.
- Fixture holes are plugged with ABS plastic caps.
- Carrier Body is 8-1/2" high x 24" deep.
- Height adjustable in 1" increments.
- End Caps must be ordered separately.
- See page J13 for configurations.

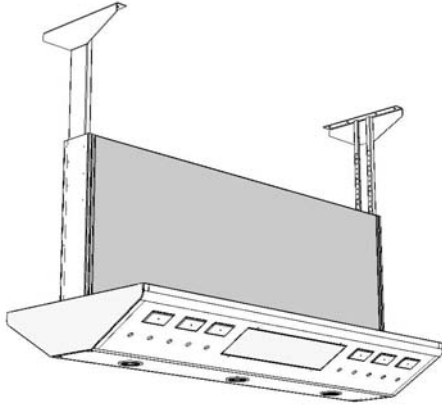
**OVERHEAD SERVICE CARRIER**
**Center Panel Assembly For Chameleon™**

Width	12" High	24" High	36" High
24"	OHP2412	OHP2424	OHP2436
30"	OHP3012	OHP3024	OHP3036
36"	OHP3612	OHP3624	OHP3636
48"	OHP4812	OHP4824	OHP4836
60"	OHP6012	OHP6024	OHP6036
72"	OHP7212	OHP7224	OHP7236

- Pair of filler panels available in three different heights, used to enclose space between ceiling assembly (middle shelf is eliminated supplying a pipe chase from carrier to the ceiling).
- Mounting hardware included.
- Suitable for Chameleon™ carrier only.

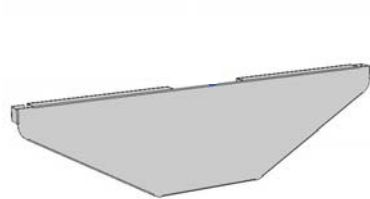
**Carrier End Cap For Chameleon™**

Item Number
OHC0000

- Single end cover cap used to enclose uncovered ends of carrier body.
- Mounting hardware included.
- Suitable for Chameleon™ carrier only.

*OVERHEAD SERVICE CARRIERS*

**Flush Mounted Chameleon™**

Flush mounted Chameleons deliver ceiling fed utilities from ceiling tiles and are available in 24" x 24" or 24" x 48" dimensions. They can house utilities like piping, electric, data, light fixtures. They provide maximum flexibility as services are lifted off the floor, allowing free floor space to be configured as needed. Ideal for use with Sigma Carts™ as the quick disconnects allow for easy relocation.

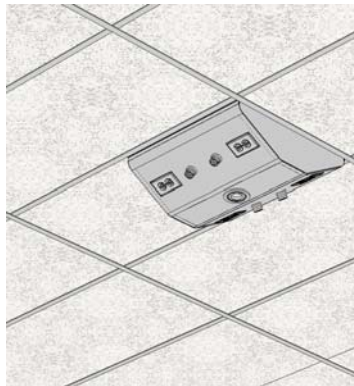
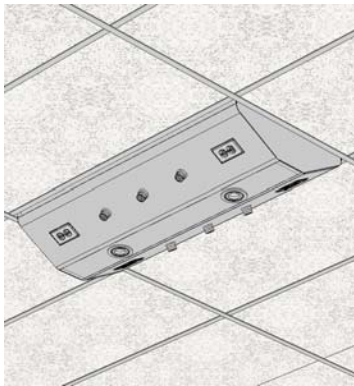

**Flush Mounted Chameleon™ Views**

**Bottom Views**

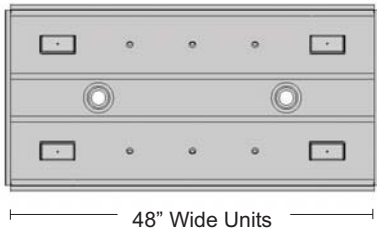

Note: Above units shown with optional lights.

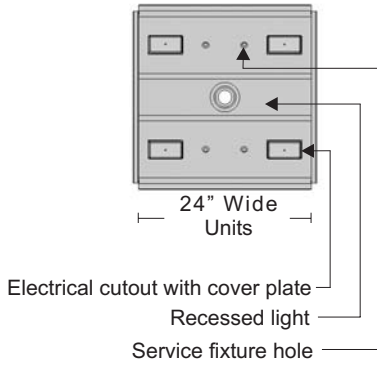

**Side Views**

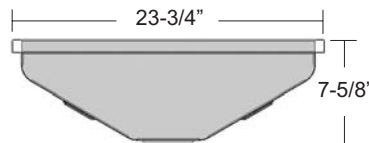

**OVERHEAD SERVICE CARRIER**
**Flush Mounted Chameleon™ With Lights**

24" x 24" model

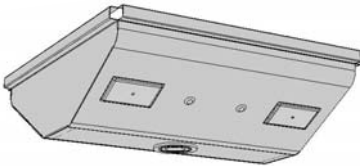

48" x 24" model

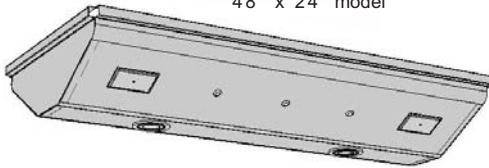

Size	Item Number
24"x24"	OHC3024
48"x24"	OHC3048

- Junction boxes are factory installed.
- Fixture holes are plugged with ABS plastic caps.
- Carrier Body is 8-1/2" high x 24" deep.
- One piece of unistrut is welded to inside of carrier frame for anchoring to support above.
- See page J16 for configurations.

**Flush Mounted Chameleon™ Without Lights**

24" x 24" model

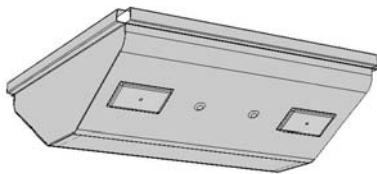

48" x 24" model

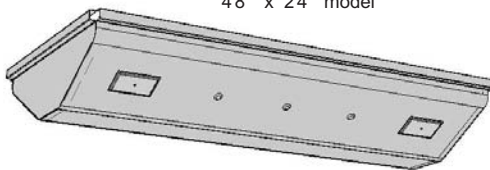

Size	Item Number
24"x24"	OHC4024
48"x24"	OHC4048

- Junction boxes are factory installed.
- Fixture holes are plugged with ABS plastic caps.
- Carrier Body is 8-1/2" high x 24" deep.
- One piece of unistrut is welded to inside of carrier frame for anchoring to support above.
- See page J16 for configurations.

**OVERHEAD SERVICE CARRIERS**

**Suspended Stratus™**

Suspended Stratus™ with sleek styling are hung from the ceiling. They can house utilities like piping, electric, data, light fixtures, and snorkel exhausts. They provide maximum flexibility as services are lifted off the floor, allowing free floor space to be configured as needed. They are height adjustable and available in various widths and come with the option of lighting.

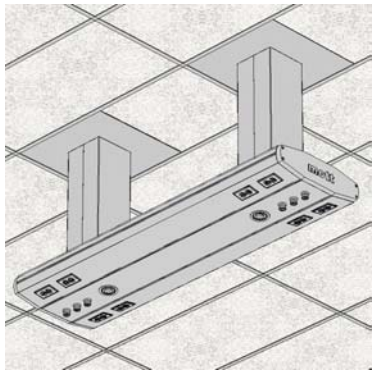

**Suspended Stratus™ Views**

**Bottom Views**

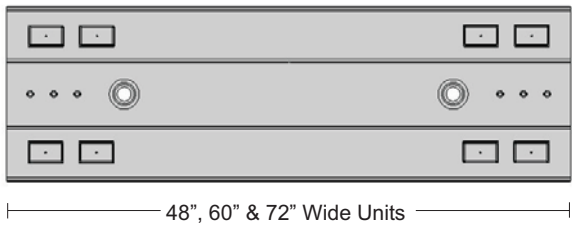

Note: Above units shown with optional lights.

**Side Views**

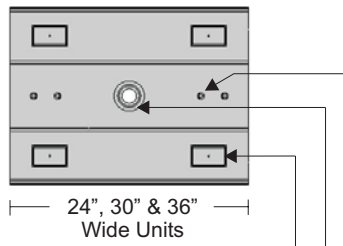
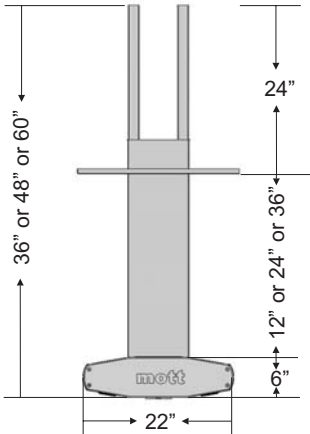

Electrical cutout with cover plate  
 Recessed light  
 Service fixture hole

## OVERHEAD SERVICE CARRIER

### Suspended Stratus™ With Lights



Width	Item Number
24"	OHS1024
30"	OHS1030
36"	OHS1036
48"	OHS1048
60"	OHS1060
72"	OHS1072

- Junction boxes are factory installed.
- Fixture holes are plugged with ABS plastic caps.
- Carrier Body is 6" high x 22" deep.
- Ceiling Assembly and End Caps must be ordered separately.
- See page J18 for configurations.

### Suspended Stratus™ Without Lights

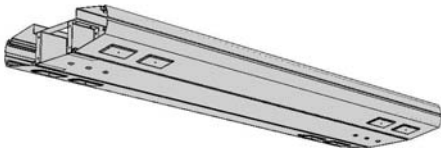

Width	Item Number
24"	OHS2024
30"	OHS2030
36"	OHS2036
48"	OHS2048
60"	OHS2060
72"	OHS2072

- Junction boxes are factory installed.
- Fixture holes are plugged with ABS plastic caps.
- Carrier body is 6" high x 22" deep.
- Ceiling Assembly and End Caps must be ordered separately.
- See page J13 for configurations.

### Vertical Column Assembly For Stratus™

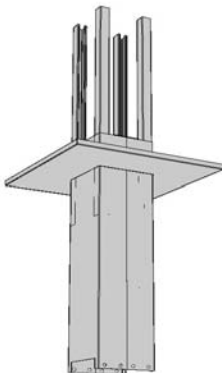

Height	Item Number
36"	OHS8010
48"	OHS8020
60"	OHS8030

- Only one Vertical Column Assembly required for 24", 30" and 36" wide carriers.
- Two Vertical Column Assemblies required for 60" and 72" wide carriers.
- Carrier body must be ordered separately.
- Suitable for Stratus™ carrier only.

OVERHEAD SERVICE CARRIER

Carrier End Cap For Stratus™

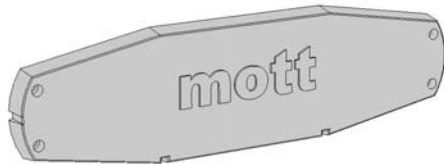

Item Number

OHS0000

- Single cast aluminum end cover cap used to enclose uncovered ends of carrier body, with raised Mott logo.
- Mounting hardware included.
- Suitable for Stratus™ carrier only.